

# Open Display Merchandisers

## European Style Open Display Cases



### FEATURES / BENEFITS

#### EFFICIENT REFRIGERATION SYSTEM

Turbo Air's Open Display Merchandisers are designed with oversized and balanced (CFC Free R-134A) refrigeration systems. These include efficient evaporators and condensers for faster cooling and greater efficiency.

#### EURO DESIGN

The Open Display Merchandiser is made from type 304 stainless steel. Elegant contemporary Euro design will enhance any store application.

#### FLUORESCENT LIGHTING ON EACH SHELF

#### ALL 300 SERIES STAINLESS STEEL INTERIOR INCLUDING BACK WALL, SHELVES AND FLOOR

#### PERFORATED INTERIOR BACK WALL AND TOP FOR IMPROVED AIR FLOW

#### FRONT AIR INTAKE AND REAR AIR DISCHARGE

#### STANDARD BACKGUARD IMPROVES AIRFLOW

#### FOAMED WITH POLYURETHANE, HIGH-DENSITY CELL INSULATION (CFC FREE)

#### ENERGY SAVING NIGHT CURTAIN STANDARD (TOM-40 & TOM-50 ONLY)

#### BOTTOM MOUNT COMPRESSOR UNITS

Turbo Air's bottom mount compressor allows easier access for service and extra storage space above. In addition, the lower area provides a cooler and less greasy operating environment which results in reduced compressor running time.

#### SELF-CONTAINED SYSTEM NO PLUMBING REQUIRED

#### RECOMMENDED OPERATING CONDITIONS

\* TOM Models are designed to operate in an environment where temperature & humidity do not exceed 75°F and 55% respectively.

\* Units should not be installed near HVAC vents, fans or doorways that will disrupt the air curtain and compromise the function of the cabinet

\* Air curtain models will run most efficiently when completely loaded with product.

Model	CU./FT.	#of Shelves	HP	AMPS	Crated Weight	L D H
TOM-40S(B)	6.7	-	1/2	8	411	39 x 31 1/9 x 42 3/5
TOM-50S(B)	9.0	-	1/2	8	463	50 4/5 x 31 1/9 x 42 3/5
TOM-40L(B)	10.5	1	1/2	8	452	39 x 35 3/5 x 47
TOM-50L(B)	14.0	1	1/2	8	505	50 4/5 x 35 3/5 x 47
TOM-40M(B)	10.6	3	1	16	521	39 x 27 1/3 x 60
TOM-50M(B)	14.1	3	1	16	567	50 4/5 x 27 1/3 x 60
TOM-40(B)	14.7	4	1	16	543	39 x 27 1/3 x 78
TOM-50(B)	19.6	4	1	16	629	50 4/5 x 27 1/3 x 78

## TOM-40(B) / TOM-50(B)

## TOM-40M(B) / TOM-50M(B) SPECIFICATIONS

MODEL	TOM-40(B)	TOM-50(B)
Exterior Dimension (LxDxH)	39x27 <sup>1</sup> / <sub>3</sub> x78	50 <sup>4</sup> / <sub>5</sub> x27 <sup>1</sup> / <sub>3</sub> x78
Interior Dimension (LxDxH)	36 <sup>1</sup> / <sub>2</sub> x14 <sup>1</sup> / <sub>5</sub> x49 <sup>8</sup> / <sub>9</sub>	48 <sup>2</sup> / <sub>5</sub> x14 <sup>1</sup> / <sub>5</sub> x49 <sup>8</sup> / <sub>9</sub>
Compressor (HP)	1	1
Voltage (NEMA-5-15P)	115V 60Hz	115V 60Hz
AMP	16A	16A
Plug-In	NEMA 5-20P	NEMA 5-20P
Shelves	4EA	4EA
Shelf Size	(1) 35 <sup>4</sup> / <sub>5</sub> x10 <sup>4</sup> / <sub>5</sub> (1) 35 <sup>4</sup> / <sub>5</sub> x10 <sup>4</sup> / <sub>5</sub> (1) 35 <sup>4</sup> / <sub>5</sub> x10 <sup>4</sup> / <sub>5</sub> (1) 35 <sup>4</sup> / <sub>5</sub> x10 <sup>4</sup> / <sub>5</sub>	(1) 47 <sup>4</sup> / <sub>5</sub> x10 <sup>4</sup> / <sub>5</sub> (1) 47 <sup>4</sup> / <sub>5</sub> x10 <sup>4</sup> / <sub>5</sub> (1) 47 <sup>4</sup> / <sub>5</sub> x10 <sup>4</sup> / <sub>5</sub> (1) 47 <sup>4</sup> / <sub>5</sub> x10 <sup>4</sup> / <sub>5</sub>
Net Weight	507lbs	573lbs

MODEL	TOM-40M(B)	TOM-50M(B)
Exterior Dimension (LxDxH)	39x27 <sup>1</sup> / <sub>3</sub> x60	50 <sup>4</sup> / <sub>5</sub> x27 <sup>1</sup> / <sub>3</sub> x60
Interior Dimension (LxDxH)	36 <sup>1</sup> / <sub>2</sub> x15x33 <sup>8</sup> / <sub>9</sub>	48 <sup>2</sup> / <sub>5</sub> x14 <sup>1</sup> / <sub>5</sub> x33 <sup>8</sup> / <sub>9</sub>
Compressor (HP)	1	1
Voltage (NEMA-5-15P)	115V 60Hz	115V 60Hz
AMP	16A	16A
Plug-In	NEMA 5-20P	NEMA 5-20 P
Shelves	3EA	3EA
Shelf Size	(1) 35 <sup>4</sup> / <sub>5</sub> x8 <sup>4</sup> / <sub>5</sub> (1) 35 <sup>4</sup> / <sub>5</sub> x9 <sup>4</sup> / <sub>5</sub> (1) 35 <sup>4</sup> / <sub>5</sub> x10 <sup>4</sup> / <sub>5</sub>	(1) 47 <sup>4</sup> / <sub>5</sub> x8 <sup>4</sup> / <sub>5</sub> (1) 47 <sup>4</sup> / <sub>5</sub> x9 <sup>4</sup> / <sub>5</sub> (1) 47 <sup>4</sup> / <sub>5</sub> x10 <sup>4</sup> / <sub>5</sub>
Net Weight	451lbs	485lbs

\*Design and specifications subject to change without notice.

\*Design and specifications subject to change without notice.

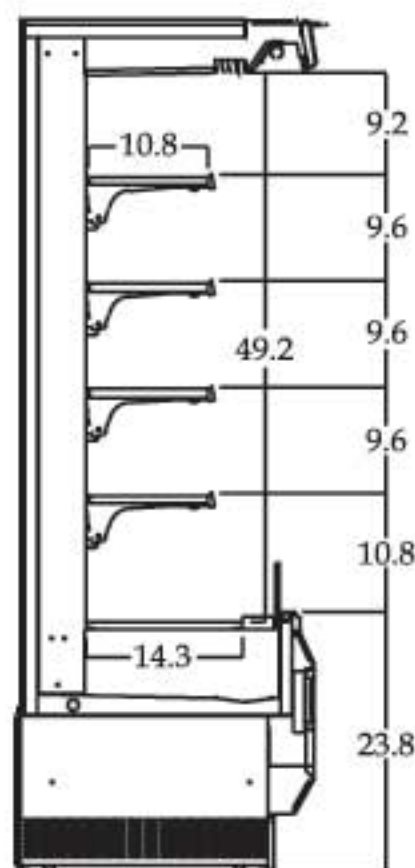

SIDE VIEW

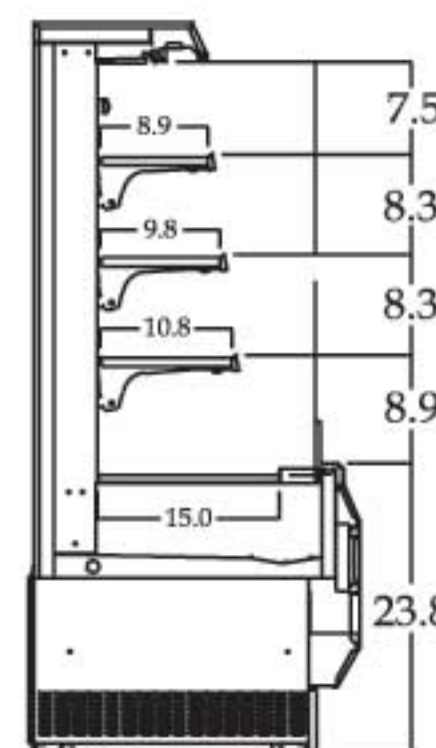

SIDE VIEW

(unit : inch)

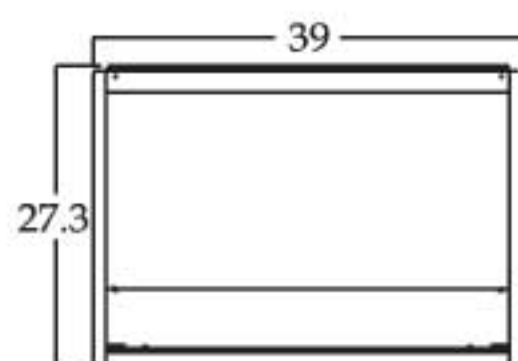

TOM-40

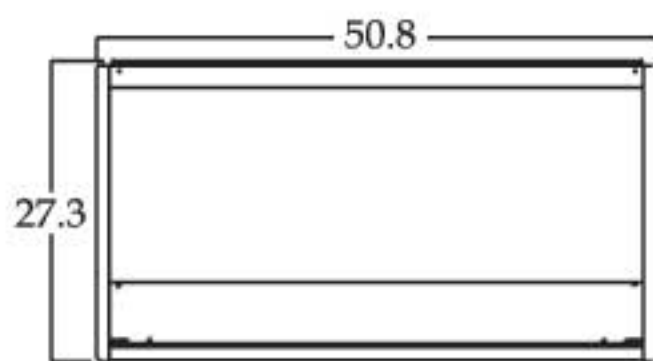

TOM-50

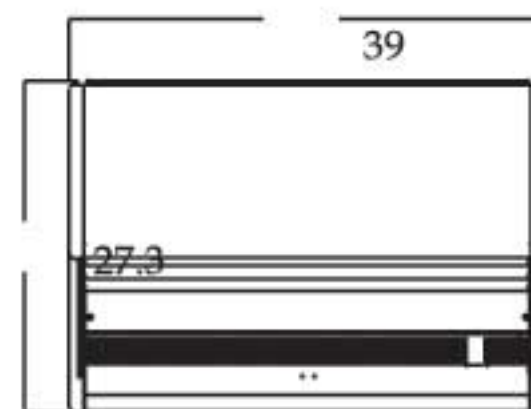

TOM-40M

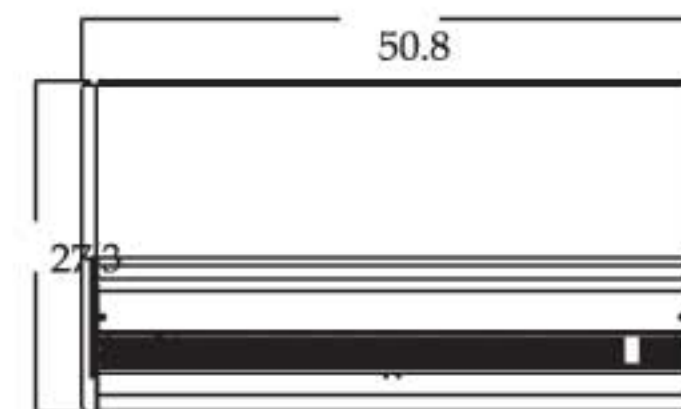

TOM-50M

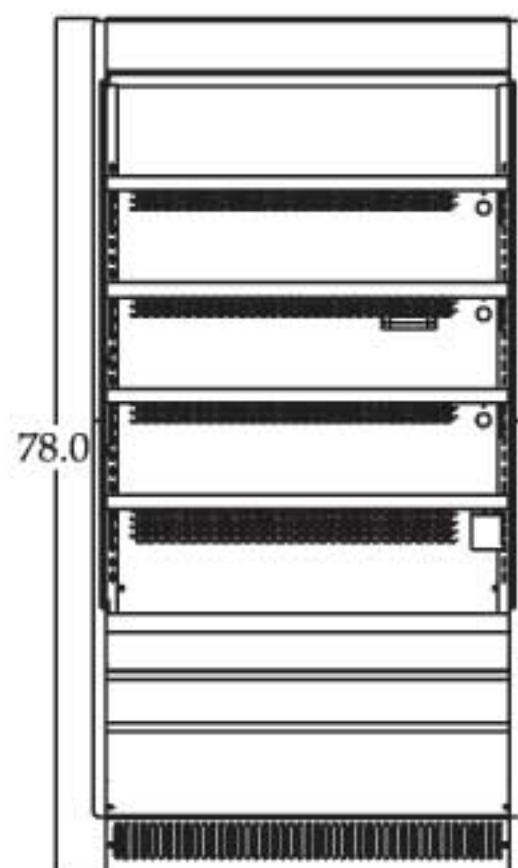

TOM-40 FRONT VIEW

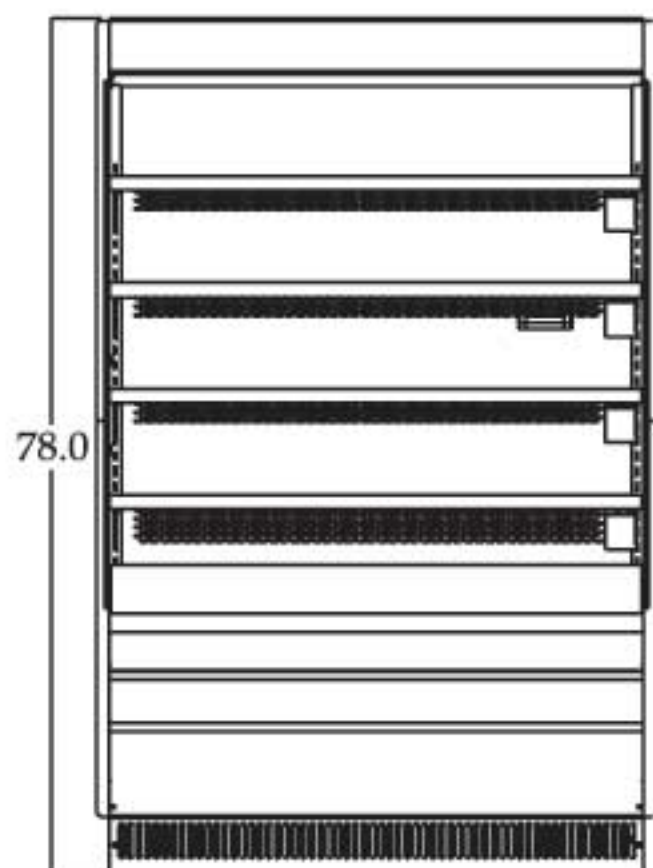

TOM-50 FRONT VIEW

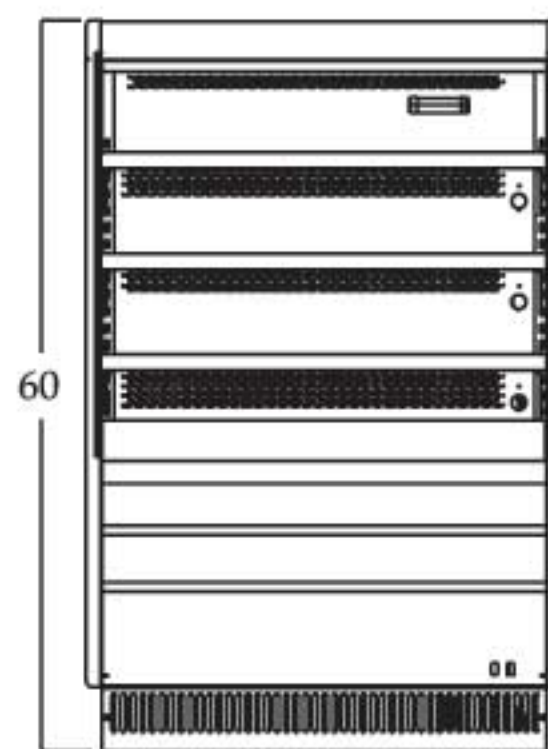

TOM-40M FRONT VIEW

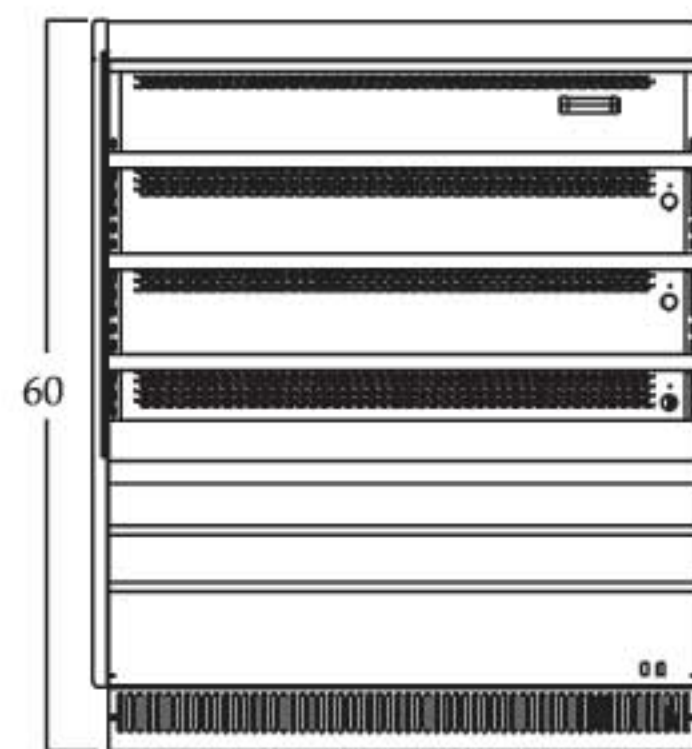

TOM-50M FRONT VIEW

# TOM-40S(B) / TOM-50S(B)

# TOM-40L(B) / TOM-50L(B) SPECIFICATIONS

MODEL	TOM-40S(B)	TOM-50S(B)
Exterior Dimension (LxDxH)	39x31 <sup>1</sup> / <sub>9</sub> x42 <sup>3</sup> / <sub>5</sub>	50 <sup>4</sup> / <sub>5</sub> x31 <sup>1</sup> / <sub>9</sub> x42 <sup>3</sup> / <sub>5</sub>
Interior Dimension (LxDxH)	36 <sup>1</sup> / <sub>2</sub> x21 <sup>4</sup> / <sub>5</sub> x15	48 <sup>2</sup> / <sub>5</sub> x21 <sup>4</sup> / <sub>5</sub> x15
Compressor (HP)	1/2	1/2
Voltage (i) NEMA-5-15P	(i)115V 60Hz	(i)115V 60Hz
AMP	8A	8A
Plug-In	NEMA 5-15P	NEMA 5-15 P
Shelves	-	-
Shelf Size	-	-
Net Weight	330 lbs	352 lbs

\*Design and specifications subject to change without notice.

MODEL	TOM-40L(B)	TOM-50L(B)
Exterior Dimension (LxDxH)	39x35 <sup>3</sup> / <sub>5</sub> x47	50 <sup>4</sup> / <sub>5</sub> x35 <sup>3</sup> / <sub>5</sub> x47
Interior Dimension (LxDxH)	36 <sup>1</sup> / <sub>2</sub> x26 <sup>1</sup> / <sub>3</sub> x19 <sup>1</sup> / <sub>3</sub>	48 <sup>2</sup> / <sub>5</sub> x26 <sup>1</sup> / <sub>3</sub> x19 <sup>1</sup> / <sub>3</sub>
Compressor (HP)	1/2	1/2
Voltage (i) NEMA-5-15P	(i)115V 60Hz	(i)115V 60Hz
AMP	8A	8A
Plug-In	NEMA 5-15P	NEMA 5-15P
Shelves	1 EA	1 EA
Shelf Size	(1) 35 <sup>4</sup> / <sub>5</sub> x10 <sup>4</sup> / <sub>5</sub>	(1) 47 <sup>4</sup> / <sub>5</sub> x10 <sup>4</sup> / <sub>5</sub>
Net Weight	396 lbs	418 lbs

\*Design and specifications subject to change without notice.

■ **WARRANTY :** 1 Year Labor and Parts Warranty  
Additional 4 Years Warranty  
on Compressor



(unit : inch)

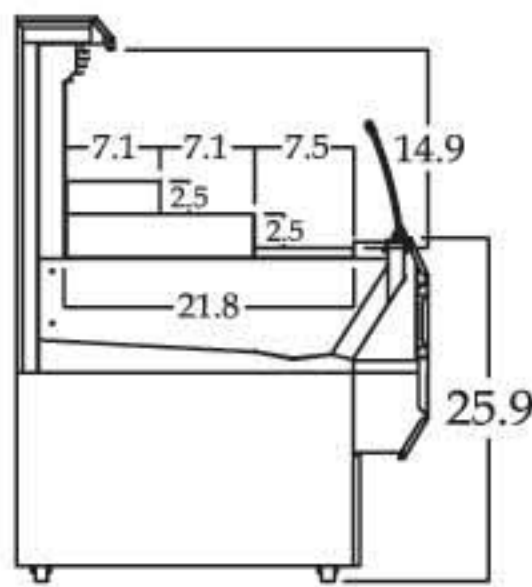

SIDE VIEW

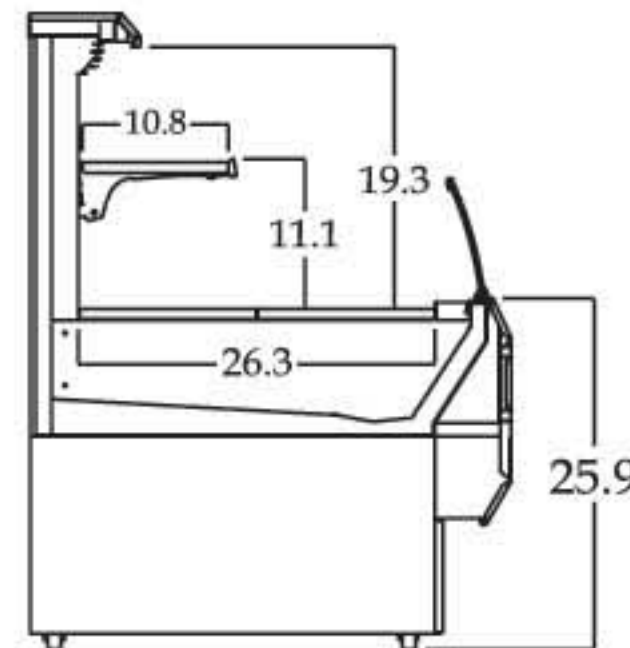

SIDE VIEW

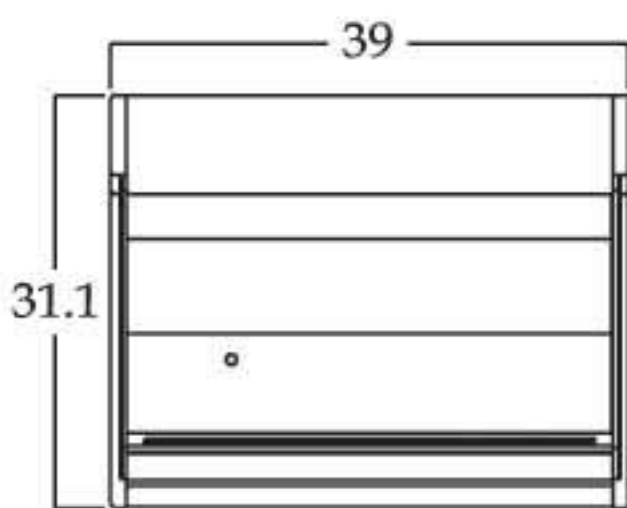

TOM-40S

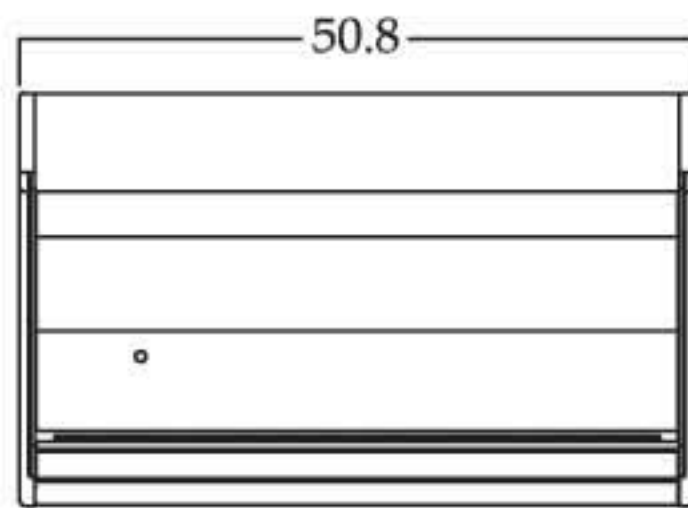

TOM-50S

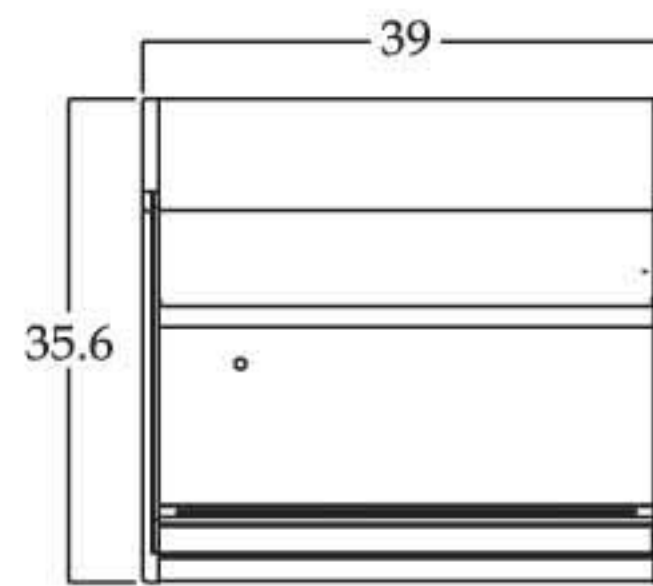

TOM-40L

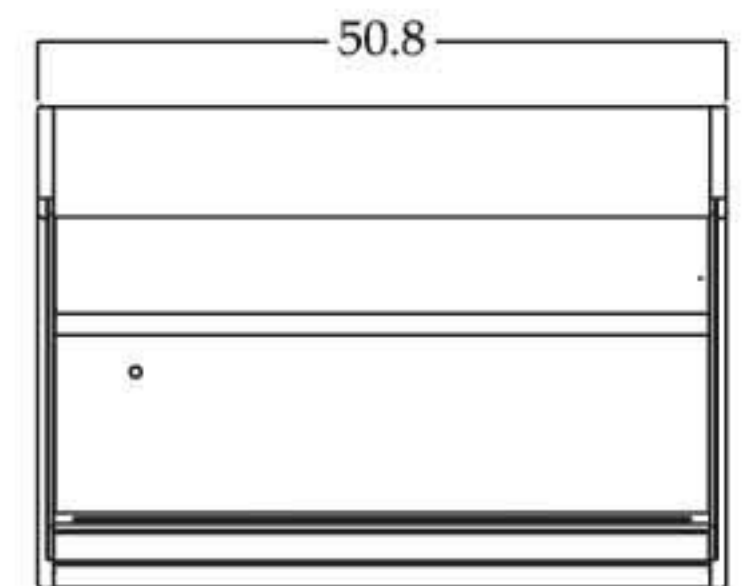

TOM-50L

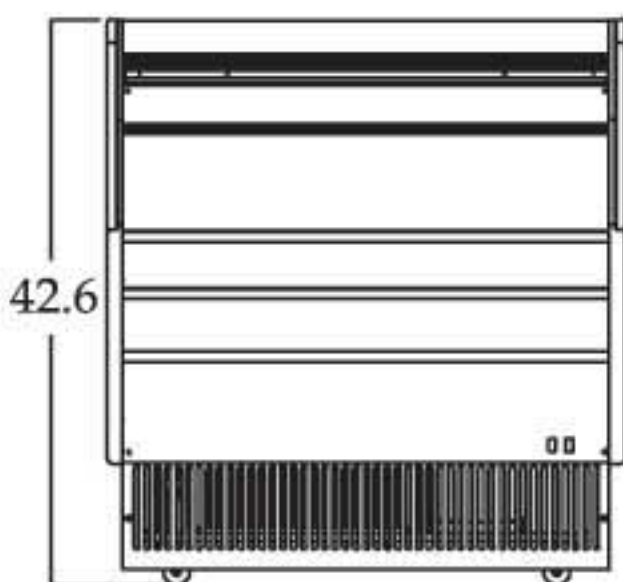

TOM-40S FRONT VIEW

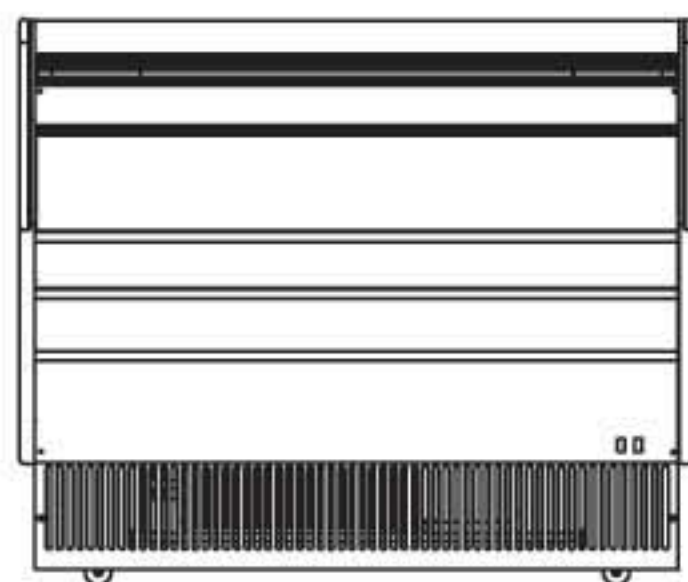

TOM-50S FRONT VIEW

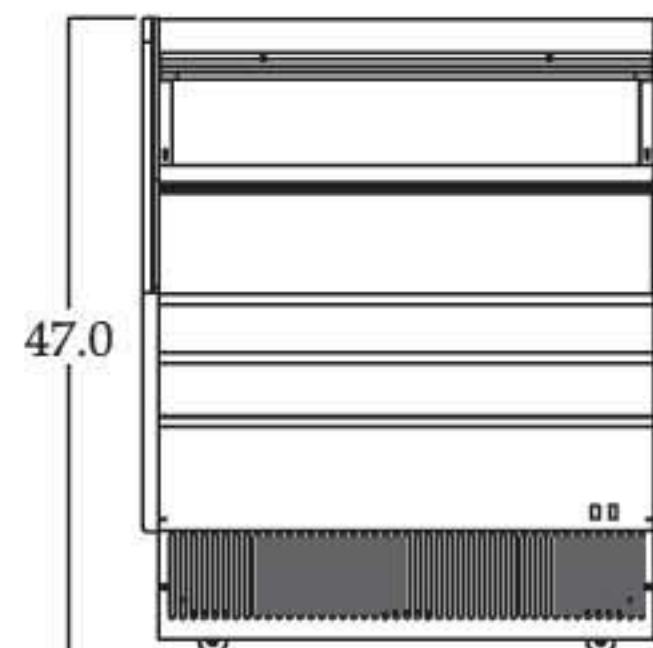

TOM-40L FRONT VIEW

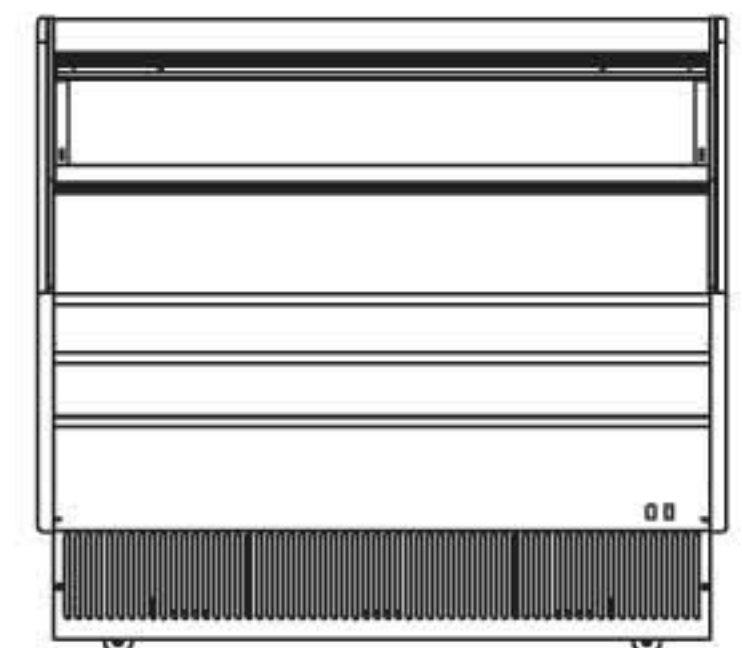

TOM-50L FRONT VIEW